



*Rewarding Learning*

General Certificate of Secondary Education  
2019

Centre Number

--	--	--	--	--

Candidate Number

--	--	--	--

---

## Physics

Unit 2

Foundation Tier

<b>MV18</b>
-------------

**[GPY21]**

**FRIDAY 14 JUNE, MORNING**

---

### **Time**

1 hour 15 minutes, plus your additional time allowance.

### **Instructions to Candidates**

Write your Centre Number and Candidate Number in the spaces provided at the top of this page.

**You must answer the questions in the spaces provided.**

**Do not write on blank pages.**

Complete in black ink only.

Answer **all five** questions.

### **Information for Candidates**

The total mark for this paper is 80.

Figures in brackets printed at the end of each question indicate the marks awarded to each question or part question.

Quality of written communication will be assessed in question **2(d)**.

1 (a) In terms of vibrations, what is meant by a transverse wave? [1 mark]

---

---

---

(b) The diagram below shows a wave.

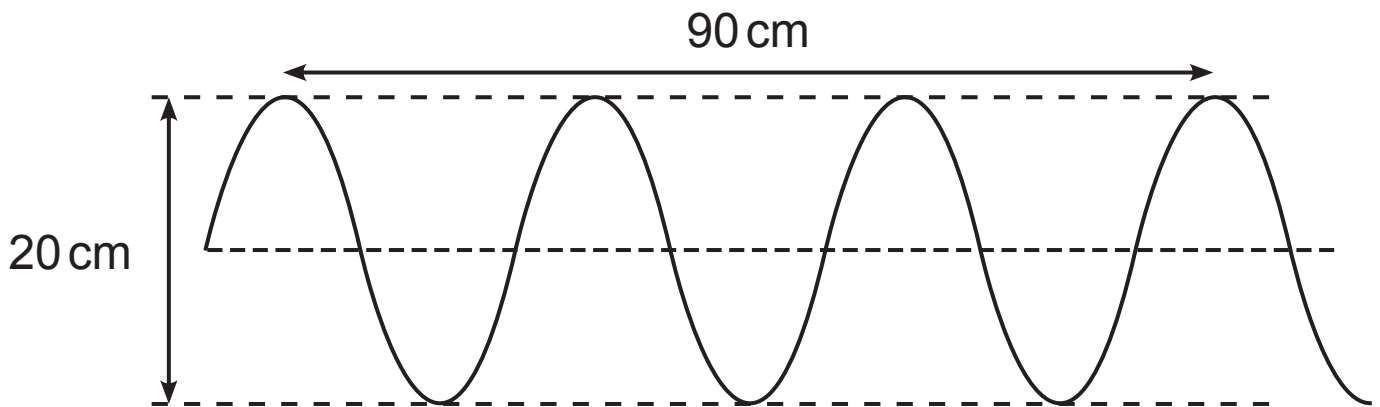

(i) Calculate the amplitude of the wave. [1 mark]

\_\_\_\_\_ cm

(ii) Calculate the wavelength of the wave. [1 mark]

\_\_\_\_\_ cm

(iii) This wave travels at a speed of 45 cm/s.

Calculate the frequency of the wave. [3 marks]

**Show clearly how you get your answer, starting with the equation you plan to use.**

Frequency = \_\_\_\_\_ Hz

(c) The diagram shows water waves moving from deep water to shallow water.

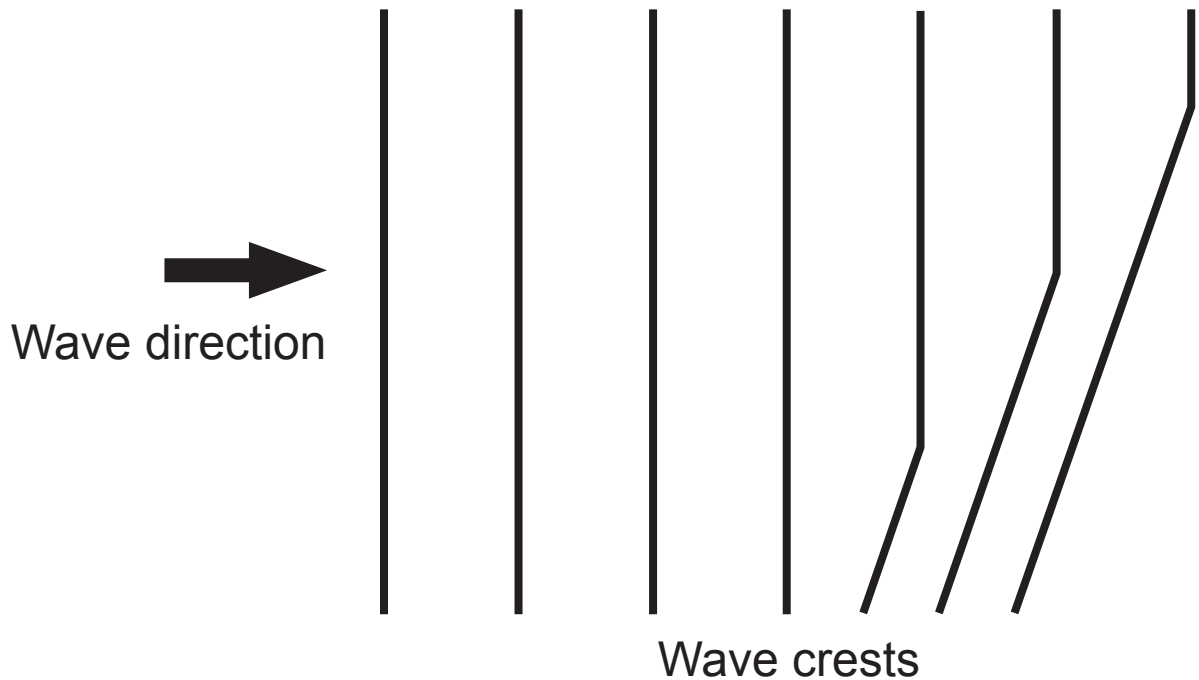

(i) On the diagram, mark clearly the boundary between the deep water and the shallow water. [1 mark]

(ii) What effect is shown in the diagram? [1 mark]

---

(iii) State **two** properties of the waves that decrease as the waves move from deep water to shallow water. [2 marks]

1. \_\_\_\_\_

2. \_\_\_\_\_

(d) A student investigates the reflection of sound using the apparatus shown below.

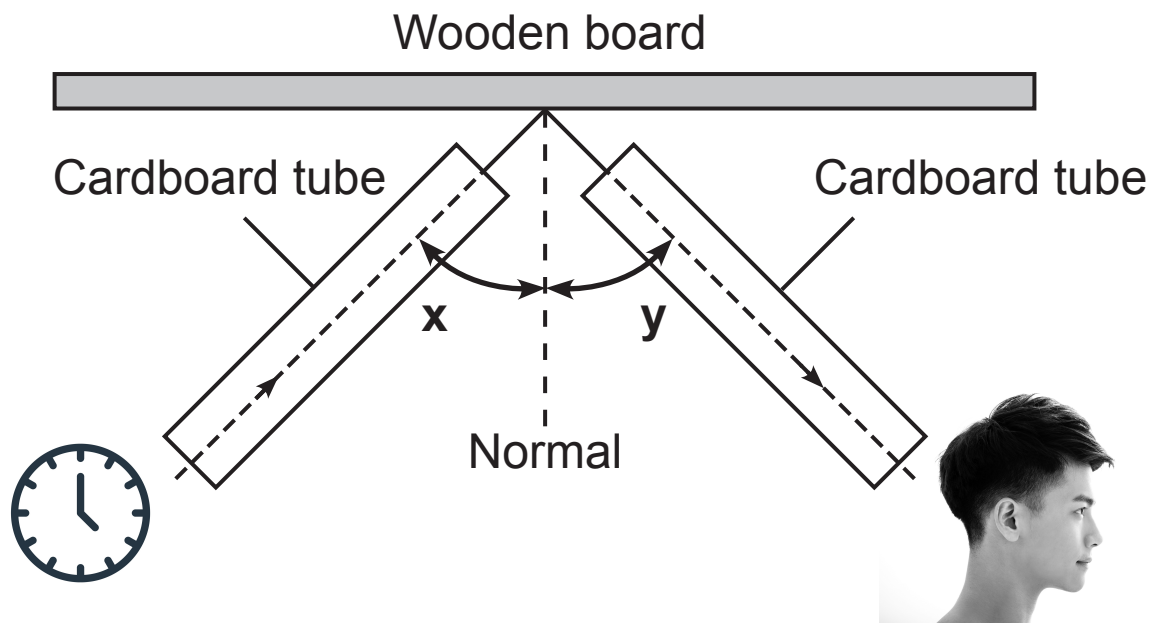

Ticking clock

(i) What is the reflection of sound called? [1 mark]

\_\_\_\_\_

(ii) The student moves the cardboard tube on the right. At what point will he notice that the sound of the ticking clock is loudest? [1 mark]

\_\_\_\_\_  
\_\_\_\_\_

The diagram below shows several people in a room. A sound absorbing barrier separates them from a source of sound as shown.

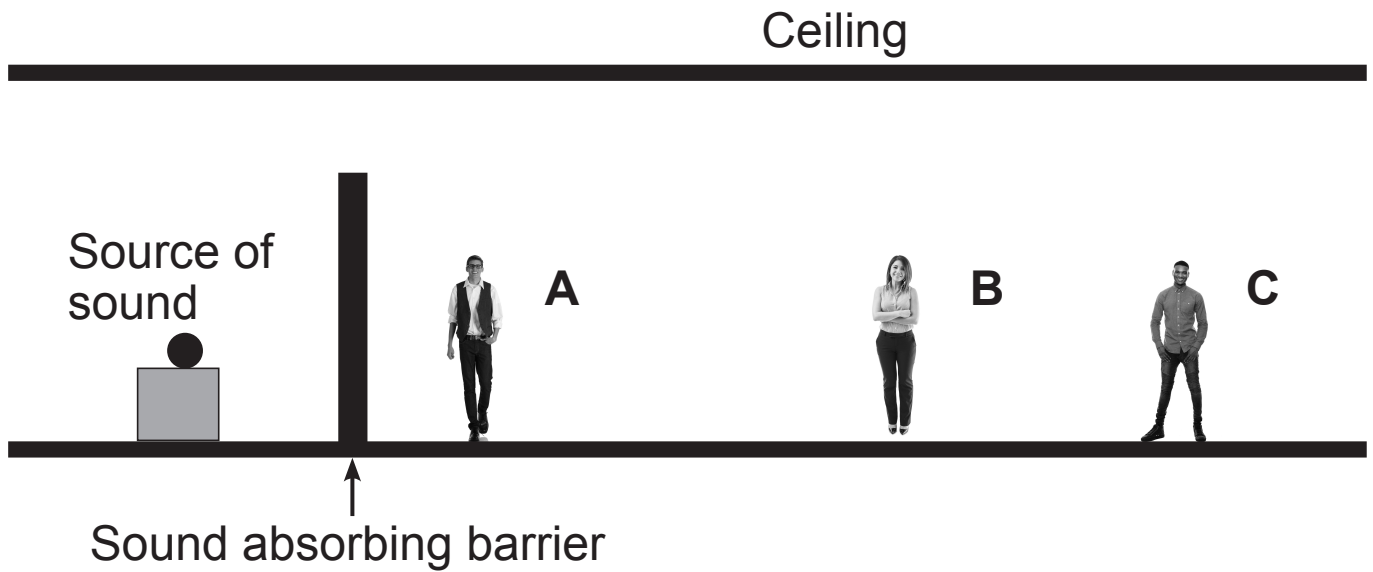

(iii) Which of the three people, **A**, **B** or **C**, can hear the sound? [1 mark]  
Explain your answer.

---

---

---

(e) Electromagnetic waves have many uses.

Answer the following questions which refer to the uses of electromagnetic waves.

(i) Which one is used to make toast? [1 mark]

\_\_\_\_\_

(ii) Which one can produce a sun tan? [1 mark]

\_\_\_\_\_

(iii) Which one allows us to see? [1 mark]

\_\_\_\_\_

(iv) Which one is used in satellite communications?  
[1 mark]

\_\_\_\_\_

(f) The use of electromagnetic waves to detect flying aircraft is known as \_\_\_\_\_ [1 mark]

(g) Name **two** properties that are common **only** to electromagnetic waves. [2 marks]

1. \_\_\_\_\_

2. \_\_\_\_\_

**Blank Page**  
**(Questions continue overleaf)**

- 2 (a) The diagram shows an object (a candle) and its virtual image as seen in a plane mirror.

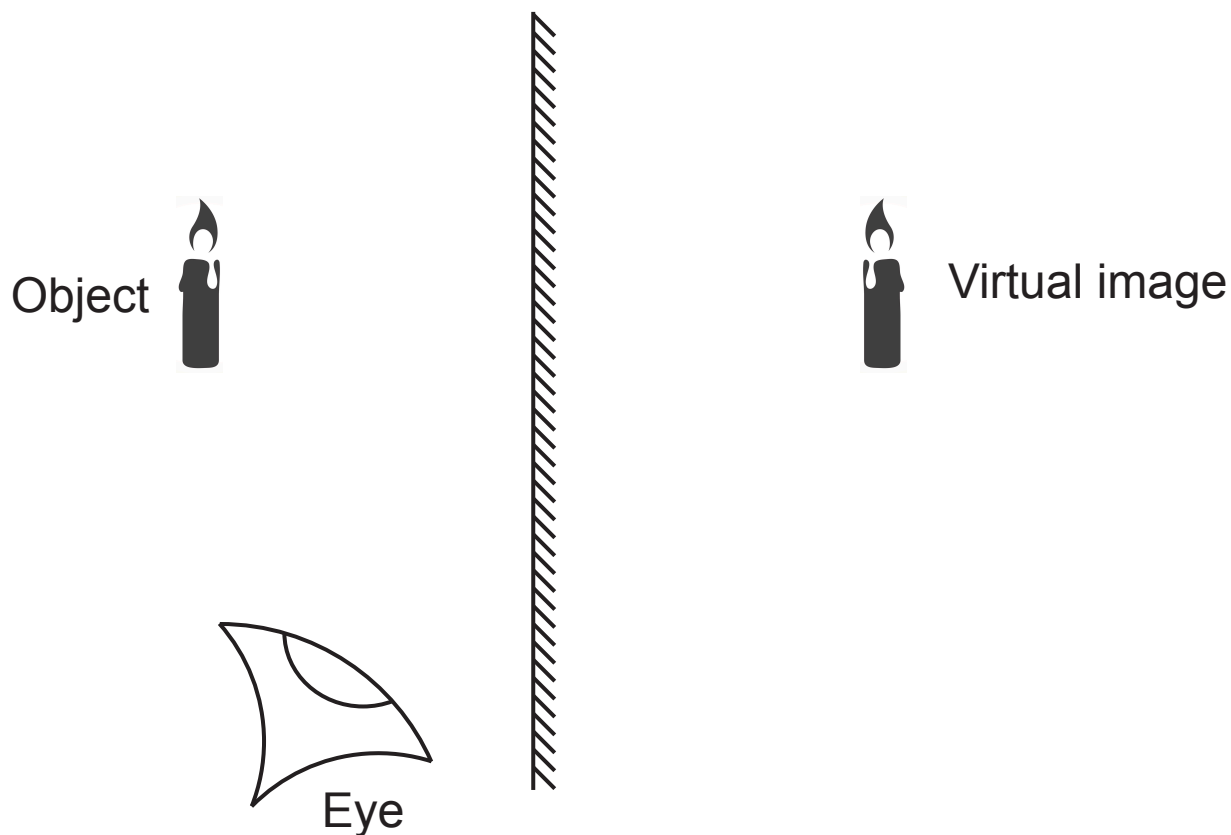

Draw one incident ray from the top of the candle flame and show how this ray is reflected from the mirror to reach the eye shown. [3 marks]

**(b)** When a beam of white light is passed through a glass prism, it is split into many colours.

**(i)** What is this effect called? [1 mark]

---

**(ii)** Explain why this happens. [1 mark]

---

---

**(iii)** Complete the diagram below by labelling the red ray and violet ray. [1 mark]

Write the colours in the boxes provided.

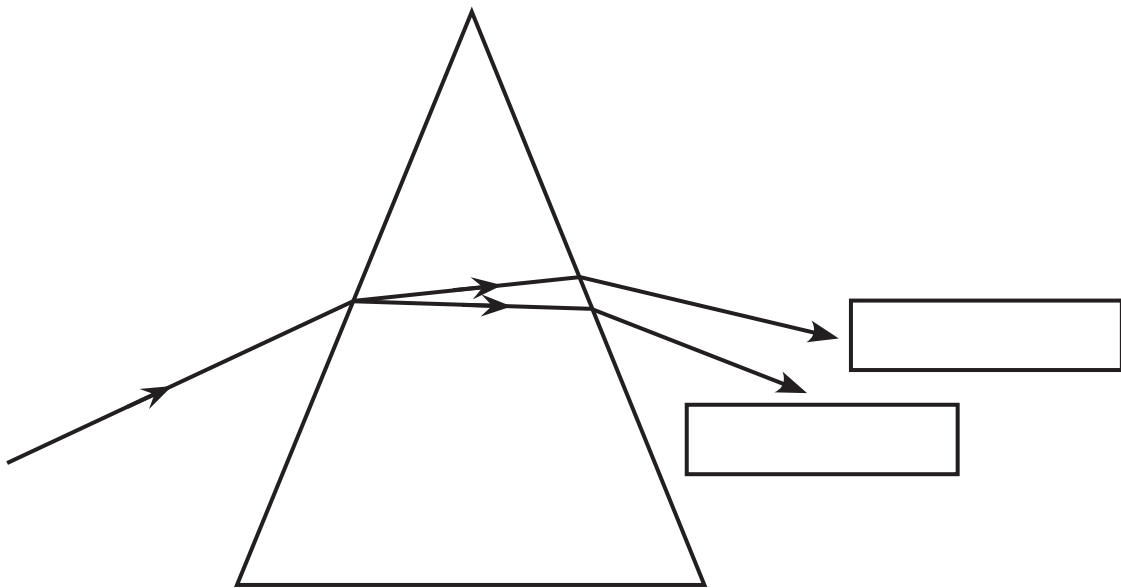

- (c) (i) Complete the ray diagram below to show how rays of light from a nearby object are refracted by the eye of a person with **normal vision**. [2 marks]

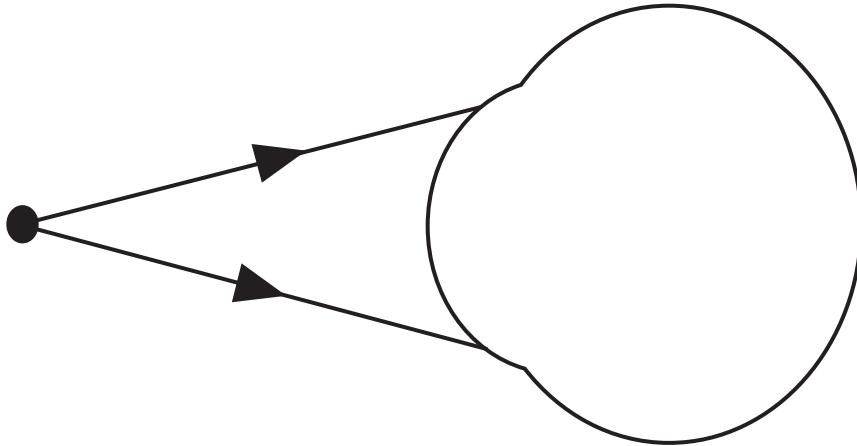

- (ii) Complete the ray diagram below to show how the rays of light from a nearby object are refracted by the eye of a person with **long sight**. [1 mark]

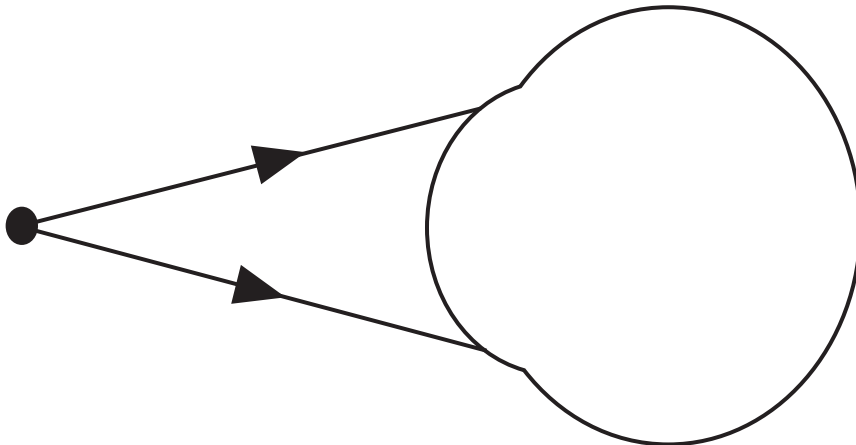

- (iii) What causes a person to have long sight?  
[1 mark]

---

---

(iv) Long sight can be corrected by using a lens in front of the eye as shown below.

Write the type of lens used to correct long sight in the box provided.

Complete the ray diagram to show the path taken by the rays through the lens and the eye. [4 marks]

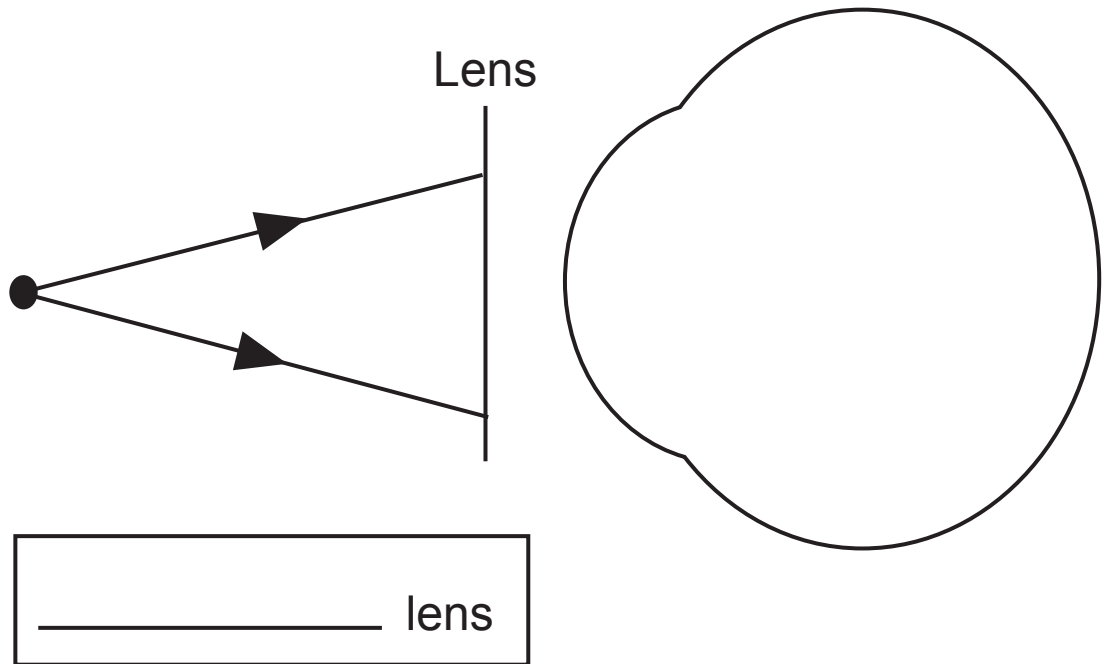

**(d)** When light travels from air into glass it is refracted. Describe how you would investigate the refraction of light as it passes from air into and through a glass block. In your description you should state the following:

- the apparatus you would use
- how the path of the refracted ray into and through the glass block is marked
- how the angles of incidence and refraction are measured
- how you would investigate, how the angle of refraction depends on the angle of incidence
- what graph you would plot to show the relationship between the angle of refraction and the angle of incidence
- what this graph would tell you.

**In this question, you will be assessed on your written communication skills including the use of specialist scientific terms.**

**Write your answers on the page opposite.**  
[6 marks]

Apparatus \_\_\_\_\_

\_\_\_\_\_

Path of a ray \_\_\_\_\_

\_\_\_\_\_

\_\_\_\_\_

\_\_\_\_\_

Measurement of angles \_\_\_\_\_

\_\_\_\_\_

\_\_\_\_\_

Investigation \_\_\_\_\_

\_\_\_\_\_

\_\_\_\_\_

\_\_\_\_\_

\_\_\_\_\_

Relationship \_\_\_\_\_

\_\_\_\_\_

\_\_\_\_\_

Graph \_\_\_\_\_



\_\_\_\_\_

\_\_\_\_\_

- 3 (a) Complete the table by identifying the component whose circuit symbol is shown and inserting the circuit symbol for the one named. [1 mark]

Component	Circuit symbol
	
Resistor	

- (b) Each cell in the batteries shown below has a voltage of 1.5 V.  
Complete the table by finding the voltage provided by each battery. [3 marks]

Battery	Voltage provided/V
	
	
	

(c) A student was investigating how the current flowing through a piece of wire, kept at constant temperature, was related to the voltage connected across it. The diagram below shows an incomplete circuit that was used.

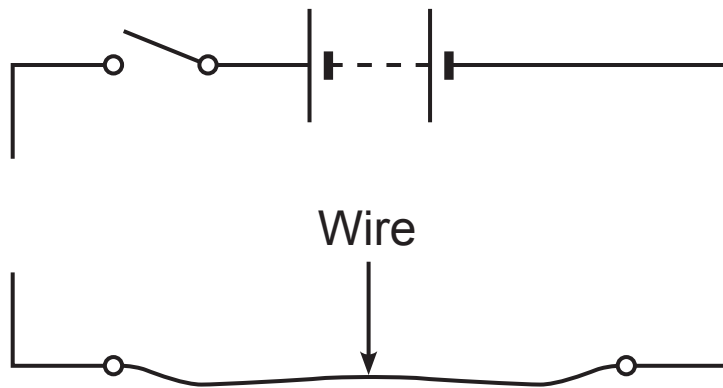

(i) Using the correct circuit symbols, complete the diagram to show where the voltmeter, ammeter and variable resistor (rheostat) should be positioned to allow readings to be taken. [3 marks]

(ii) Explain why a variable resistor is included in the circuit. [1 mark]

---



---

(iii) From the readings obtained, the student plotted the points on a grid, shown below. Identify the anomalous point on the grid by drawing a circle around it. [1 mark]

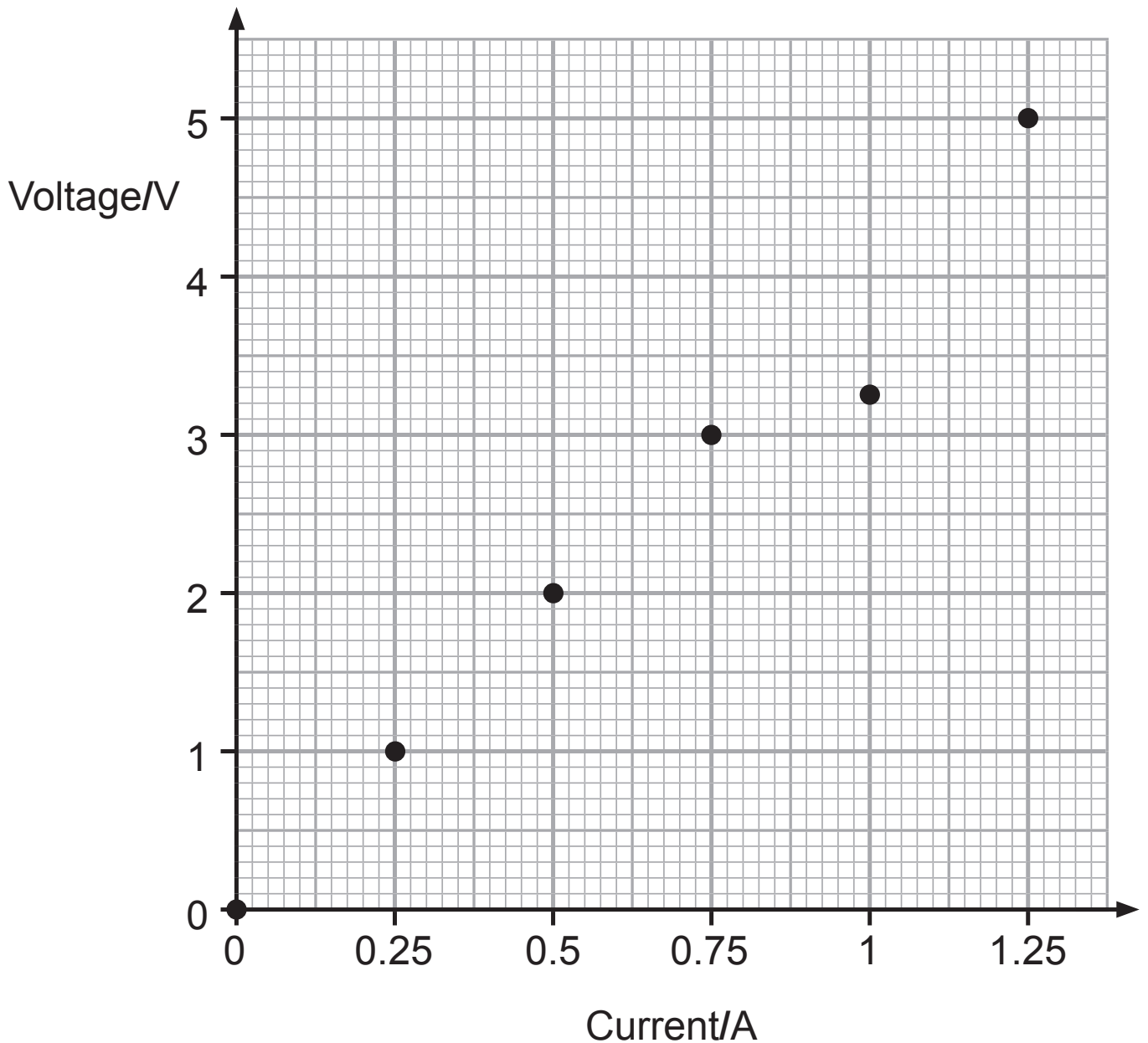

(iv) Draw the line of best fit on the grid. [1 mark]

(v) Are the current and voltage directly proportional?

Explain your choice. [1 mark]

Directly proportional (Yes/No) \_\_\_\_\_

Explanation \_\_\_\_\_

\_\_\_\_\_

(vi) Using the graph, calculate the resistance of the wire.

[3 marks]

**You should show clearly how you obtain your answer.**

Resistance = \_\_\_\_\_  $\Omega$

(d) The brake lamps in a car are labelled 12 V, 24 W.  
Two possible circuits for the brake lamps are shown below.

**Circuit 1**

Push switch on  
brake pedal

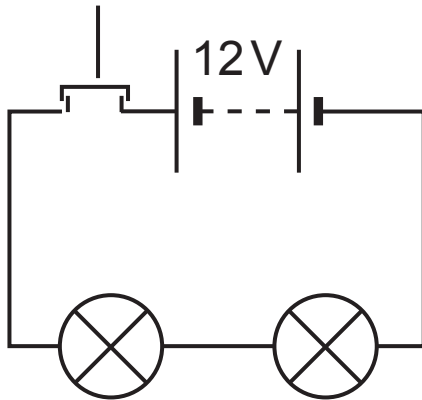

**Circuit 2**

Push switch on  
brake pedal

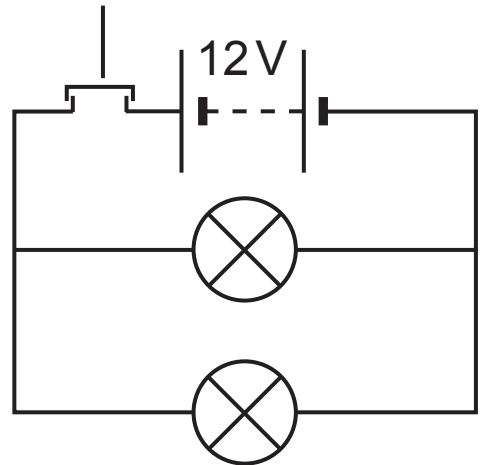

(i) In circuit 1, what is the voltage across each lamp?  
[1 mark]

Voltage = \_\_\_\_\_ V

(ii) In circuit 2, what is the voltage across each lamp?  
[1 mark]

Voltage = \_\_\_\_\_ V

(iii) If one bulb failed, in which circuit would the other bulb continue to light? [1 mark]

\_\_\_\_\_

**(iv)** Calculate the current flowing through the lamp when it is operating at the required brightness. Remember the bulbs are labelled 12 V, 24 W.

[3 marks]

**Show clearly how you get your answer, starting with the equation you plan to use.**

Current = \_\_\_\_\_ A

4 (a) The diagram below shows two coils of wire, each wrapped around an iron core.

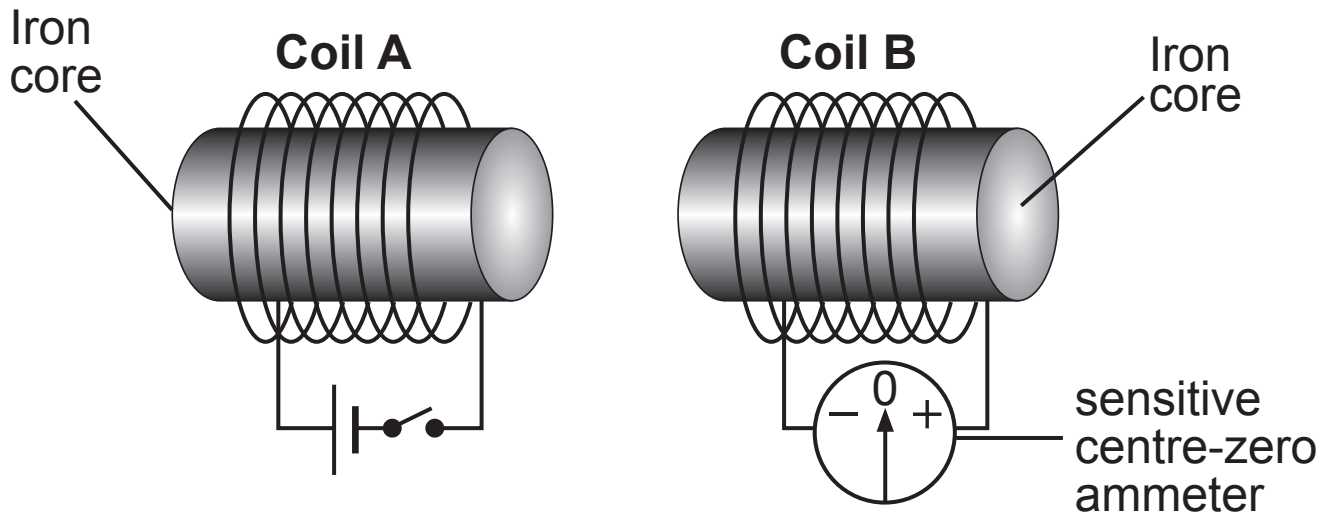

Describe what is observed on the centre-zero ammeter when the following actions are taken. [4 marks]

Write your answers in the spaces provided.

Action	Observation
The switch attached to coil A is closed.	
The switch remains closed and coil B is moved towards coil A.	
The switch attached to coil A is opened.	
The switch attached to coil A remains open and coil B is moved away from coil A.	

**(b)** A radio needs 6.0 V to operate.

This is achieved by connecting it to a transformer which in turn is connected to the 240 V mains supply as shown below.

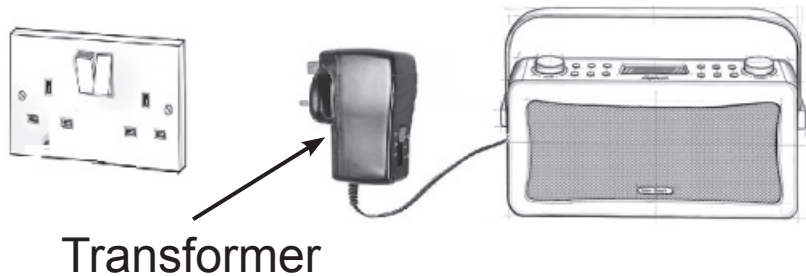

The diagram below shows the structure of the transformer used above.

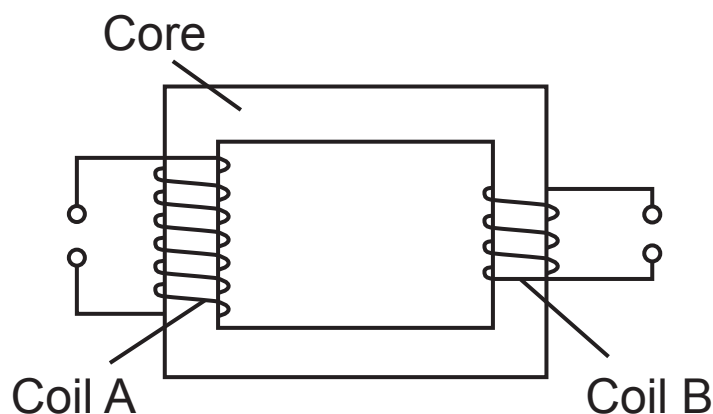

**(i)** What type of transformer is shown above?  
[1 mark]

\_\_\_\_\_

**(ii)** Which voltage is connected to coil A? [1 mark]

\_\_\_\_\_

**(iii)** The input voltage is an a.c. supply.  
What type of voltage is the output voltage?  
[1 mark]

\_\_\_\_\_

(c) The unit used in calculating the cost of electricity to a consumer is the kilowatt-hour.

(i) Calculate the number of kilowatt-hours used when a 5 kW heater is switched on for 1 hour. [1 mark]

Number of kilowatt-hours = \_\_\_\_\_

(ii) Calculate the cost of having a shower using a 10 kW heater for 15 minutes. [2 marks]

The cost of one unit of electricity is 14 pence.

Cost = \_\_\_\_\_ pence

5 (a) The diagram shows the planets of our solar system.

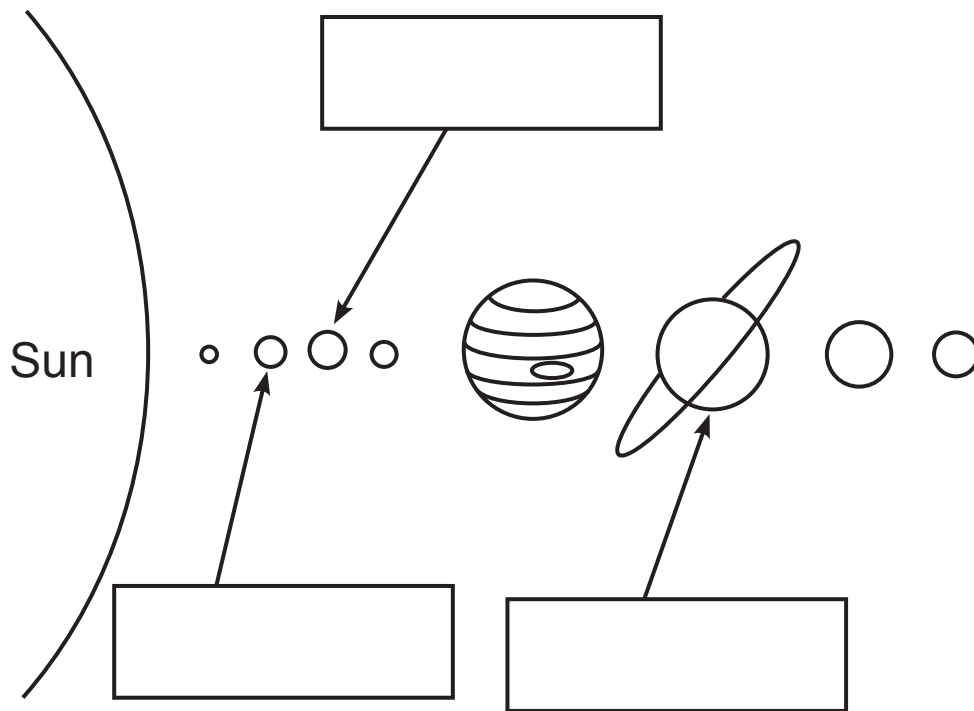

(i) Name the planets marked with arrows. [3 marks]  
Write the names in the boxes provided.

(ii) Name the force needed to keep the planets in orbit around the Sun. [1 mark]

\_\_\_\_\_

(iii) What **two** elements are the main constituents of our Sun? [2 marks]

1. \_\_\_\_\_

2. \_\_\_\_\_

**(b)** Planets outside our solar system are known as exoplanets.

To date several thousand such planets have been found. Astronomers cannot see such planets but their existence is observed as they pass in front of the star they orbit.

The diagram below shows a planet passing in front of a star.

**(i)** Complete the graph to show how the brightness of the star changes as the planet passes in front of it. [2 marks]

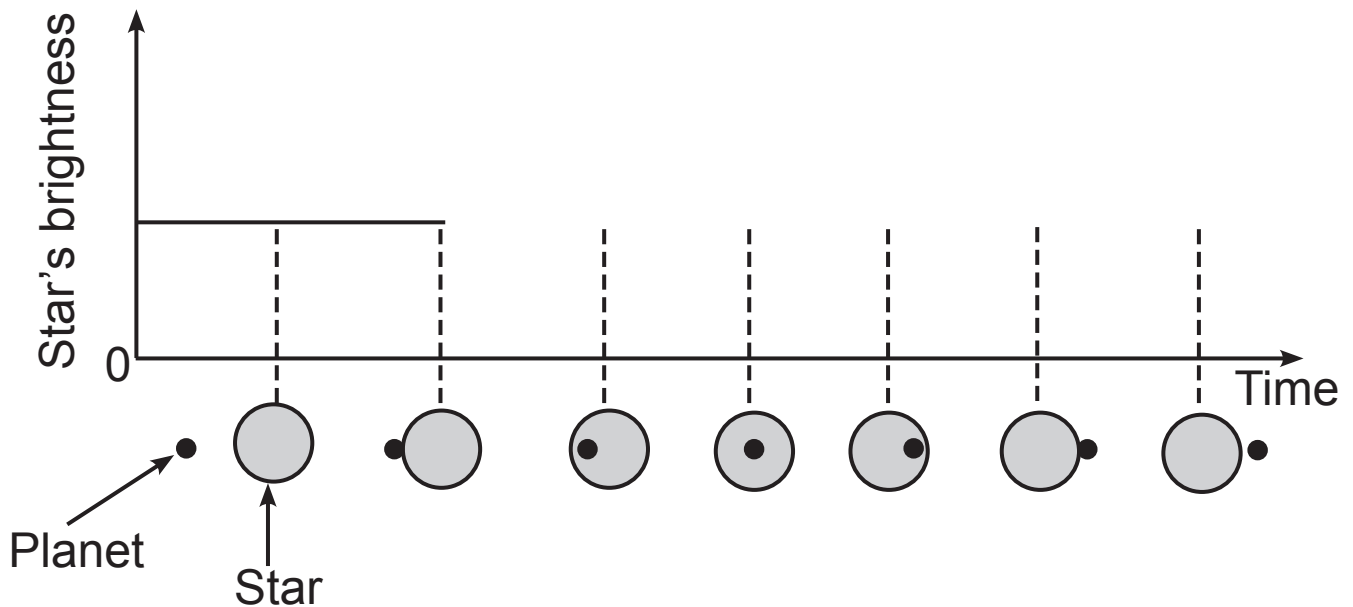

The search for life on such planets is an important part of investigating these planets.

**(ii)** What gas in the planet's atmosphere is important in this search? [1 mark]

\_\_\_\_\_

**(iii)** The nearest exoplanet to Earth is over 4 light years away.

State **one** limitation of travelling to this planet that our present technology in space travel presents.

[1 mark]

---

---

---

---

**This is the end of the question paper**

---





**SOURCES:**

Q1(b) .....Source: Chief Examiner

Q1(d) .....Source: Diagram by Chief Examiner / Images of clock and head © Getty Images

Q1(d)(ii) .Source: Chief Examiner

Q1(d)(iii).Source: Diagram by Chief Examiner / Photos © Getty Images

Q2(a).....Source: Diagram by Chief Examiner / Candle © Getty Images

Q4(a) .....Source: Chief Examiner

Q4(b) .....Source: Chief Examiner

Q5(a) .....Source: Chief Examiner

Q5(b)(i) ..Source: Chief Examiner

For Examiner's use only	
Question Number	Marks
1	
2	
3	
4	
5	
<b>Total Marks</b>	

Examiner Number

Permission to reproduce all copyright material has been applied for.  
In some cases, efforts to contact copyright holders may have been unsuccessful and CCEA will be happy to rectify any omissions of acknowledgement in future if notified.